



ghibli

USER MANUAL V.1.2

ENGLISH VERSION
05 2019



AYRTON
Digital Lighting

SUMMARY

| | |
|----|--|
| 4 | Introduction |
| 4 | Safety instructions |
| 4 | Conditions of use |
| 5 | Presentation and features |
| 6 | Dimensions |
| 7 | Description |
| 7 | Installation instructions |
| 8 | Installation method using truss hooks |
| 8 | DMX512 connection |
| 9 | Control Panel |
| 10 | Ghibli control panel menu - Option details |
| 14 | Master/Slave Mode settings |
| 15 | DMX Chart |
| 17 | Error Messages |
| 18 | Care and maintenance |
| 18 | Technical Specifications |
| 19 | Warranty |

INTRODUCTION

Thank you for selecting the AYRTON GHIBLI luminaire.

WARNING !

This product is not suitable for household use.

You now own a professional lighting unit that offers endless possibilities. Before installing, make sure that no damage was done to your luminaire during transport. If this is the case, do not use the product and immediately contact your authorized AYRTON dealer.

For your own safety and that of others, please read this instruction manual carefully before installing the unit.

Anyone involved in installing, operating or servicing the GHIBLI must:

- Be a qualified, authorized professional
- Strictly follow the instructions in this user manual.

Please take the time to read this manual carefully and thoroughly before installing and operating the luminaire. You should have a good knowledge of its operating conditions and all pertinent product information.

After you have become familiar with this manual, we recommend that you keep a copy for future use. All the information found in this manual is subject to change without notice. AYRTON reserves the right to modify and upgrade its range of products, with no obligation to integrate these changes into products already sold.

SAFETY INSTRUCTIONS

Please read the safety instructions and warnings in this manual carefully before installing and operating the GHIBLI.

WARNING!

Risk of electric shock.

Use caution when handling. This luminaire requires high voltage, which can result in electric shock.

The GHIBLI left our factory in perfect working condition. However, if you notice a defect, immediately contact your authorized AYRTON dealer before use. The manufacturer cannot be held responsible for damages caused by a failure to follow the safety, installation or assembly instructions contained herein, or by any modification made to the luminaire.

Failure to observe the safety, installation or assembly instructions contained herein, or any modification made to the GHIBLI luminaire will render the warranty null and void.

Check that the supply voltage does not exceed the maximum authorized limit. Check that your electrical installation complies with current standards.

In all cases, make sure that the power cables attached to your GHIBLI have not been damaged due to cuts and splices or crushed in any way. Handle these cables with extreme caution while they are connected to a

power source.

Your GHIBLI conforms to Class 1 safety standards. The unit must be grounded electrically. Make sure that the power source connected to your GHIBLI is switched off before attempting any work on it.

Installation and connection to an electrical source must be performed by an authorized installer. AYRTON declines all responsibility should this luminaire be installed by an unqualified person.

Never disconnect your GHIBLI by pulling on the power cable! First unlock the connector lock ring on the power cable until it is fully disengaged, and then gently pull on the connector to disconnect the cable.

Do not connect or disconnect the power cable of your GHIBLI with wet hands.

At first use, your GHIBLI may give off an odor. This is a normal occurrence that should dissipate after a few minutes of operation.

WARNING!

Do not connect or disconnect the power cable at your GHIBLI if the cable is energized! This could cause arcing and damage your GHIBLI, requiring repair.

Be careful to power off your GHIBLI by removing the power plug from the source, before connecting or disconnecting the luminaire.

WARNING!

This unit contains Class 2 LED emitters (EN60625-1: 1994) Blue Light Hazard : Risk Group 2

Never look directly into the lamps if lit or stand directly in line with the luminaire if close by.

Installation, removal or replacement of the unit must be performed with power off to prevent any risk of glare and eye injury.

WARNING!

The fixture quickly becomes very hot during operation.

To avoid risk of burn, never handle or adjust the luminaire while it is energized and after it has been lit for more than 10 consecutive minutes. Some parts of the luminaire can reach a high temperature, particularly the body/radiator. Turn off the luminaire and wait for it to cool before handling.

CONDITIONS OF USE

Your GHIBLI is a moving-head luminaire equipped with LED source intended for professional use (e.g., architectural, stage, television, theater, or museum lighting).

The GHIBLI luminaire has an IP20 protection rating. It is intended strictly for indoor use. It must never be partially or fully submerged, even temporarily.

Condensation may form on your GHIBLI in the following cases:

- Immediately after turning on the heating
- In places with fog or a high level of humidity
- When the luminaire is suddenly moved from a cold to a warm environment, or vice versa.

In such cases, you must wait until the luminaire readjusts to the ambient temperature of the room where it will be installed for operation.

Do not shake the GHIBLI while installing or handling.

Do not pull the GHIBLI by one of its cables to move it. Lift the luminaire by its handles.

Choosing the appropriate place to install the GHIBLI is essential. The following points should be observed:

- Do not expose it to a heat source.
- Do not install it near flammable materials.
- Be sure that dust or miscellaneous debris cannot clump around the body of the luminaire as this may interfere with its optimal cooling and proper operation.
- The GHIBLI must be installed out of reach of the public and all persons not authorized to operate the luminaire.

We recommend a minimum distance of 5 m between the outside surface of the light and the illuminated object.

Due to the nature of its cooling principle, you should never prevent air from circulating around the body of the luminaire. You must provide a minimum clearance around your GHIBLI to allow for cooling.

The GHIBLI can be installed in a ground pit or any other confined enclosure only under certain conditions. With this kind of installation, a system of forced ventilation should be used up to allow air to circulate freely around the luminaire(s). The air must be constantly renewed because the luminaire cannot be operated in closed system. Failure to comply with these requirements may destroy or prematurely wear the GHIBLI, and AYRTON cannot be held responsible. Please consult your AYRTON dealer for more information on this type of installation.

No load should be placed on the GHIBLI. The fixture must not be installed in such a way as to allow a person, vehicle or any object to run over or park on it.

Never lay or drop any hard, heavy, or blunt, objects on the GHIBLI. This includes items made of glass or porcelain (e.g., bottles, dishware, or glass beads). The luminaire is made of materials such as plastic and extruded aluminum, making it resistant but not unbreakable. Objects made of hard materials such as steel or glass that fall on the unit may cause breakage of the plastic parts or the body. AYRTON cannot be held responsible for the luminaire's broken plastic parts or body, which are not covered under warranty.

The temperature of the room where the GHIBLI is installed must never exceed 45°C (Ta = 45°C).

The GHIBLI luminaire requires a 110-240 VAC supply voltage. Check that your luminaires have been installed for an application that is compatible with this information.

Check that the brackets on which you hang or attach your GHIBLI can sustain the weight of the luminaire (35,6 kg), taking into consideration all

necessary safety factors.

Do not use your GHIBLI before being familiar with these recommendations and do not allow unqualified personnel to handle the product.

To transport your GHIBLI, we strongly recommend that you use the complete original packaging, including the dense protective foam inserts.

If your GHIBLI is not being used for a long period, you should disconnect the luminaire from the power source.

Never dispose of the GHIBLI in a rubbish bin. Ensure that it is recycled. Please consult the current legislation in your country on recycling electronic equipment.

PRESENTATION AND FEATURES

GHIBLI is a non-waterproof moving head wash light (IP20 protection rating) using the latest generation of high-performance of LED-type lamps.

This luminaire can be controlled remotely by an external DMX512 signal.

The GHIBLI incorporates high power white LED source.

The luminaire requires from 36 to 58 DMX channels to be controlled via an external command system that sends a DMX512 signal (see below for details).

To adjust the settings on the GHIBLI (i.e., DMX address, DMX operating mode and other options), a Remote Device Management (RDM)-type DMX controller may be required. The DMX RDM protocol is a universal, widely used standard.

There are a multitude of RDM DMX controllers on the market from different manufacturers (excluding AYRTON). It is worth noting that an RDM DMX controller is not required to change the settings on the GHIBLI. A light console or any standard DMX-type controller is sufficient.

The GHIBLI consists of a metal frame and plastic covers. The power connectors and DMX512 signal connectors are on the back of the fixture's base.

DIMENSIONS

Bottom view

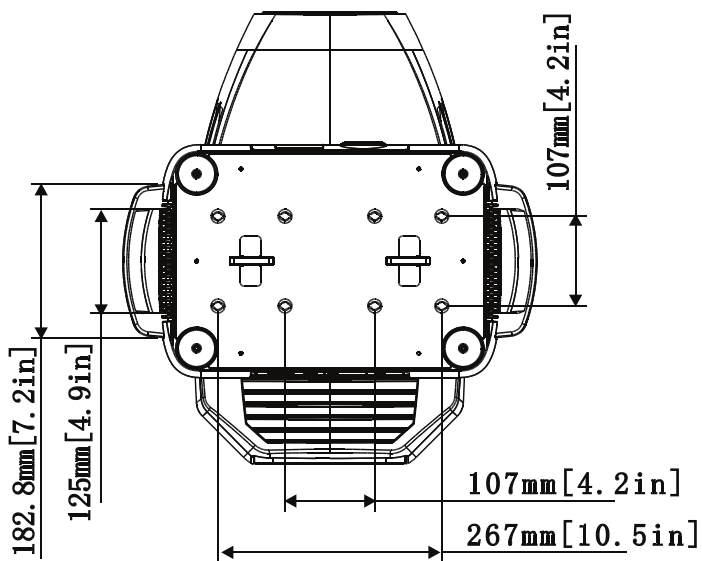

Side view

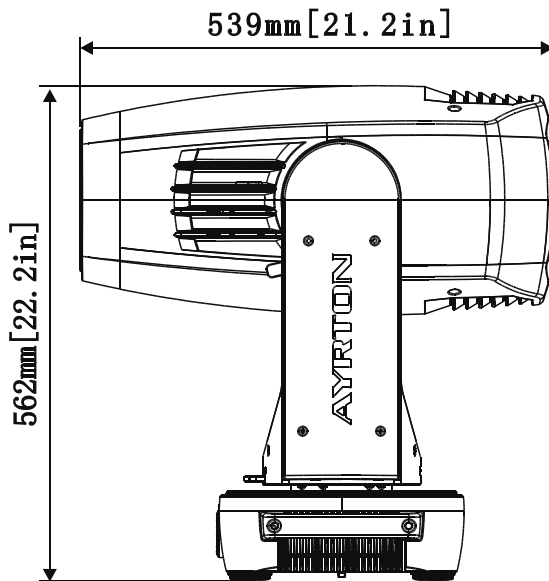

Front view

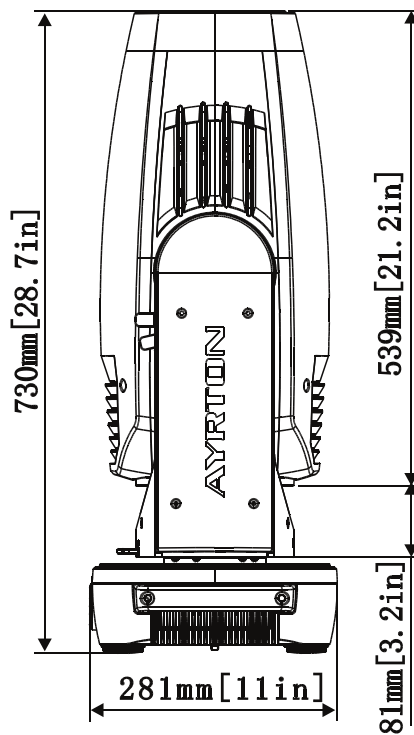
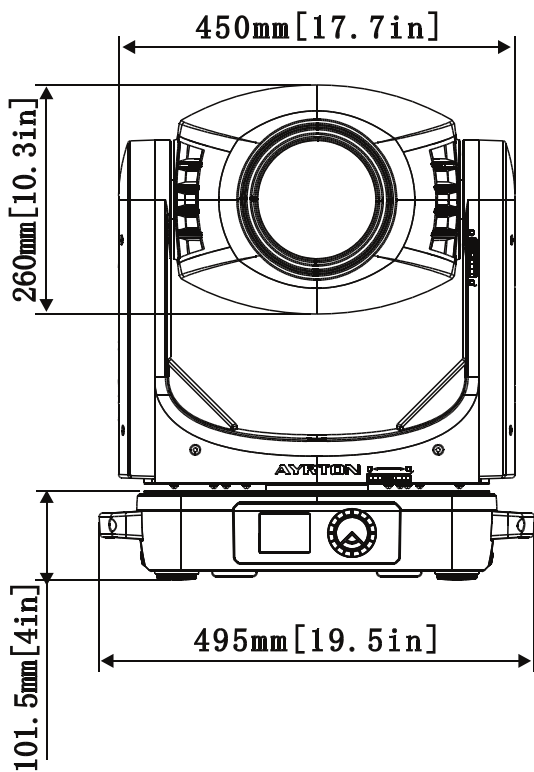

DESCRIPTION

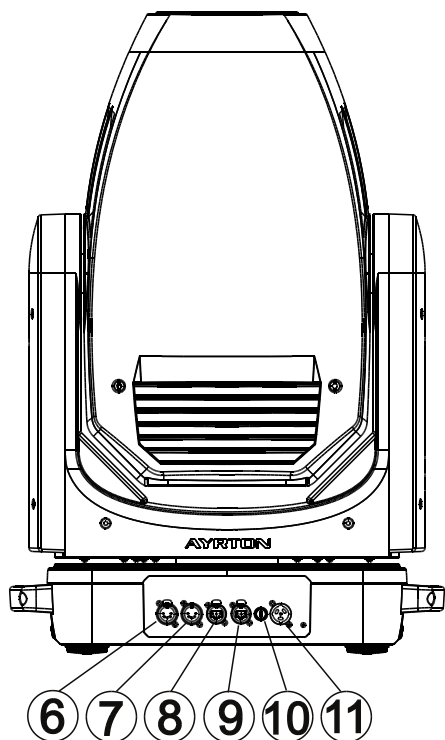
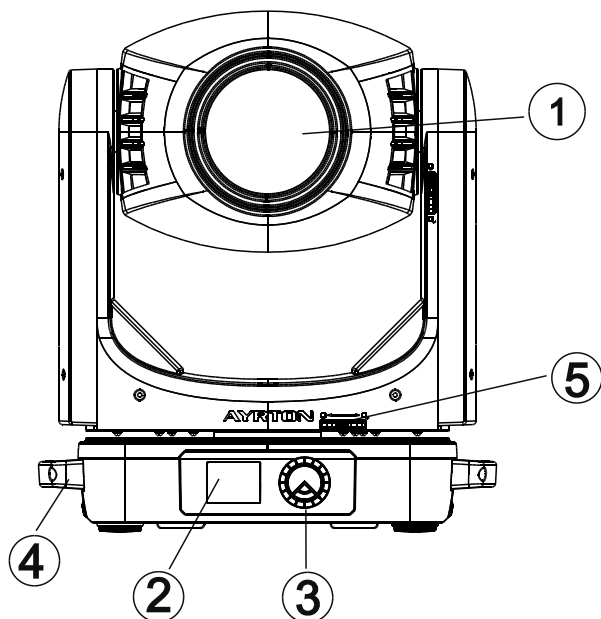

1. Lens output
2. Display
3. Jog wheel
4. Handle
5. Pan Lock button
6. DMX Out
7. DMX In
8. RJ45 Out
9. RJ45 In
10. Fuse
11. Power In

INSTALLATION INSTRUCTIONS

During installation please observe the instructions according to GB7000.15 / EN60598-2-17 standards and other national standards applicable. This luminaire should be installed by a qualified technician.

The fixture should be used in an environment with a temperature between -5°C and +45°C. Do not operate the luminaire outside this temperature range.

The luminaire must be hung so that the weight of this unit multiplied by 10 can be sustained for 1 hour without causing the suspension system or the supporting structure to be deformed.

The installation must always be secured at a second attach point, e.g., by a safety cable of the appropriate size.

Do not stand under the luminaire while it is being installed, dismantled or serviced.

The operator must ensure that a qualified technician has approved the installation of the luminaire for safety before it is first operated.

Installation should be inspected once a year by a qualified technician.

WARNING!

The installation of this luminaire must be validated by a qualified technician before it is used for the first time.

The luminaire should be installed in a location where the public cannot touch, walk or sit on the luminaire.

Suspending the luminaire and/or installing it high up requires considerable experience, e.g., calculating load, selecting and adapting quality fastening materials, and periodically inspecting the entire installation. Without this skill and knowledge, do not attempt to install this unit by yourself. Improper installation may cause an accident resulting in personal injury or death.

WARNING!

The luminaire should be connected to an electrical source by a qualified electrician.

Before installing the luminaire make sure that the selected installation spot can support at least 10 times the weight of the unit. Connect the luminaire to the power source by the power cord.

INSTALLATION METHOD USING TRUSS HOOKS

Refer to the following diagram when installing the Ghibli with truss hooks using omega bracket:

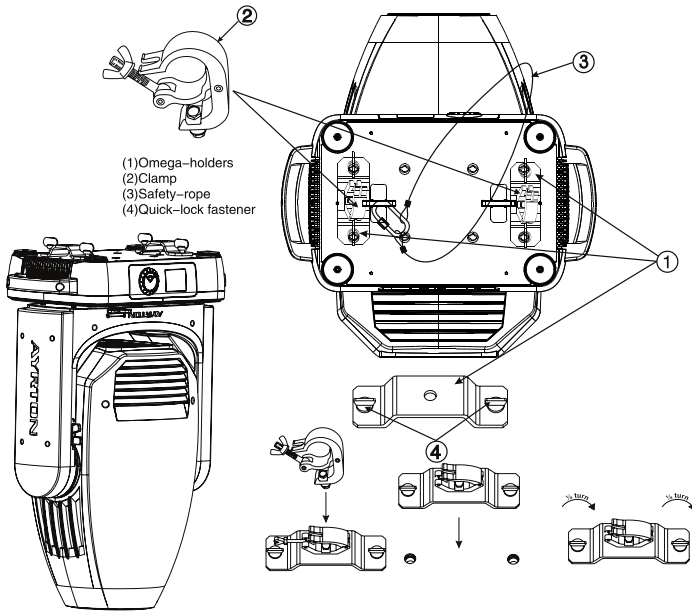

- Attach the clamp to the omega bracket using an M12 screw.
- Insert the quick-lock fasteners of the first omega bracket into the respective holes on the base of the unit. Turn the quick fasteners fully clockwise.
- Install the second omega bracket.
- Insert the safety cable through the holes at the bottom of the base and the truss or a stable attachment point. Insert the end into the hole and tighten the safety screw.

Note: The last step is very important to ensure that the luminaire does not fall.

DMX512 CONNECTION

Connect the DMX input (XLR connector) cable of the luminaire to the DMX output (female XLR connector) of your controller. You can connect multiple luminaires to this same DMX line in a daisy chain. The DMX cable must be a shielded twisted pair that is equipped with male and female XLR connectors.

Refer to the following diagram when connecting the Ghibli luminaires in a daisy chain:

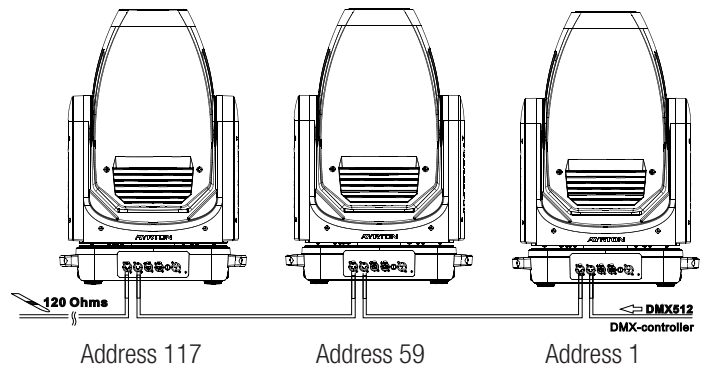

DMX512 CONNECTION WITH TERMINATION PLUG

For installations where the DMX cable must extend over long distances, or if it is located near areas with major electrical disturbance, it is recommended to use a DMX termination plug. This helps prevent luminaires from malfunctioning due to interference. The DMX termination plug, composed simply of a male XLR input connector with a 120-Ohm resistor, is soldered between pins 2 and 3. This plug must be connected to the DMX output of the last luminaire in the chain.

Refer to the following diagram:

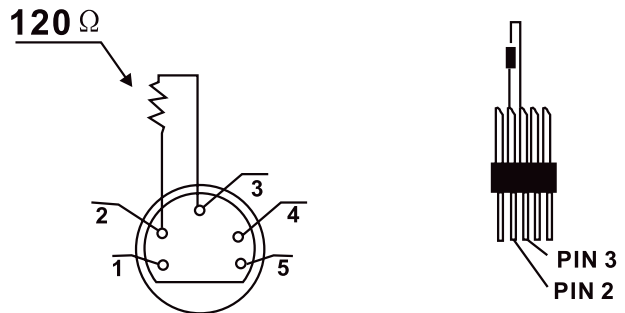

USING DMX VIA ART-NET

To control the Ghibli via ART-NET, the fixtures must be interconnected with CAT5 RJ45 cable. Be careful to enter all necessary information into the ART-NET universe being used and specify in the menu that the Ghibli is being controlled through ART-NET (see OPTION DETAILS in the « OPTIONS » menu).

WARNING!

The Ghibli can only read the first hundred universes of an ART-NET package. If you have more than 100 universes in your network, you must use a configurable switch to filter each RJ45 output.

THE Ghibli DMX ADDRESS SETTING

All luminaires must have a DMX start address correctly set when using a DMX signal to control them. The DMX start address is the channel from which the luminaire "listens" to the digital control information sent by the

DMX controller.

The start address must conform to the one set on the DMX controller to control the luminaire. This address is the DMX value that appears on the luminaire's display. You can set the same address for all the luminaires, or some of them, but you can also set a different address for each luminaire, as needed.

If you do set the same address for all the luminaires, they will all "listen" from the DMX channel you have set. The instructions sent by the DMX controller will affect all luminaires at the same time. If you set a different address per luminaire, the DMX controller can control each independently.

If, for instance, the fixtures are preset in 58-channel DMX mode (required for full control), you will need to adjust the DMX address for the luminaires as follows: The first unit with DMX address 001, the second with DMX address 059 (58 + 1), the third with DMX address 117 (58 + 59), etc.

CONTROL PANEL (MENU OPTIONS)

A large number of settings are accessible from the fixture's control panel. A good working knowledge of it will enhance the fixture's possibilities.

You can access the Main Menu by clicking the jog wheel.

Turning the jog wheel performs cycling through the menus:

Display can be activated without external power source if optional battery is installed into the unit.

Battery specs are:

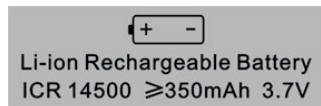

The fixture's menu functions are described in the following table:

Table 1: GIBLI MENU FUNCTIONS AND OPTIONS

| Address | Address | DMX address:001-XXX: | DMX address setting | |
|---------|------------------|---|---|---|
| Mode | User Mode | Stand Mode Basic Mode Extend Mode User Mode A User Mode B User Mode C | User's mode to change channel numbers | |
| | Edit User ModeA: | Max channel PAN : | Preset User modes A,B,C: | |
| Options | Status | No DMX Mode Pan Reverse Tilt Reverse Pan Degree Feedback Pan/Tilt Spd Hibernation Art-Net to DMX | Close/Hold/Auto ON/OFF ON/OFF 630/540 ON/OFF Speed 1 ~ 4 OFF , 01M~99M ON/OFF | |
| | Service PIN | Service PIN RDM UID Set IP Crossload SW | Password=XXX xxx.xxx.xxx.xxx Service Password"=050" Set IP Uploading Software | |
| | Fans Control | Head Control | Auto Stage Studio Silent | Fans Speed select |
| | Disp.Setting | Shutoff Time Flip Display Key Lock DispFlash | 02~60m 05m ON/OFF ON/OFF ON/OFF | Display shutoff time Reverse 180 degree Key Lock DispFlash |
| | Signal Select | DMX WDMX Art—Net sACN | | DMX WDMX Art—Net sACN |
| | Set Universe | xx | | Art-Net Universe NO. |
| | Temp. C/F | Celsius Fahrenheit | | Temperature °C/°F |
| | Initial Pos. | PAN =XXX | | Initial effect position |
| | Wireless DMX | Activate WDMX Act&Data Out Rest WDMX | | Activate WDMX Act&Data Out Rest WDMX |
| | Dim Curve | Square Law Linear | | Dimming curve |
| | Refresh Select | 1.2K 2.4K 16K | | Frequency |
| | Trigger | DMX Value Disp. Set To Slave Auto Program | PAN Slave1, Slave2, Slave3 Master / Alone | DMX Value Disp. Set To Slave Auto Program |
| | Reset Default | ON/OFF | | Restore factory sett. |
| Info | Time Info. | Current Time Til Life Hrs Last Run Hrs Timer PIN Clr Last Run | XXXX(Hours) XXXX(Hours) XXXX(Hours) Password=XXX ON/OFF | |
| | Temp. Info | Head Temp. | XXX °C/°F | |
| | Software Ver | V1.0... | Software version | |
| | Network | IP,Mask,Mac | Network setting | |
| Test | Home | All Pan&Tilt Color Gobo Other | Reset All Reset Pan&Tilt Reset Color Reset Gobo Reset Others | |
| | Test Channel | PAN | Test function | |
| | Manual Ctrl. | PAN =XXX : | Manual control of parameters | |
| | Calibration | --Password-- PAN : | Password "050" Calibrate and adjust the home position | |
| Preset | Select Prog. | Prog. Part 1 = Program 1 ~ 10 Program 1 Prog. Part 2 = Program 1 ~ 10 Program 2 Prog. Part 3 = Program 1 ~ 10 Program 3 | Select the program to be run | |
| | Edit Prog. | Program 1 : Program 10 | Program Test Step 01=SCxxx Step 64=SCxxx | |
| | Edit Scenes | Edit Scene 001 ~ Edit Scene 250 | Pan, Tilt, --Fade Time-- --Scene Time-- External input | |
| | Scenes Input | XX-XX | Scenes Input | |

GHIBLI CONTROL PANEL MENU – OPTION DETAILS

The following section provides details on the options that can be selected through the control panel menu. Refer to the table above.

Note: You can exit this menu at any time by pressing “Mode Esc” repeatedly until you return to the home screen.

ADDRESS

SET DMX ADDR

Allows you to change a DMX address from the fixture’s control panel.

- ◆ Double click jog wheel to access main menu.
- ◆ The display will show “ADDRESS”.
- ◆ Double click to access the menu “Set DMX Address”.
- ◆ Turn the jog wheel clockwise and set the DMX address “A001~Axxx”.
- ◆ Double click to confirm
- ◆ Long click the jog wheel to exit the menu – “Set DMX Address” then back to main menu by long click again.

MODE

USERS MODE

With this function, you can choose between different DMX modes.

- ◆ Double click jog wheel to access main menu
- ◆ Turn the jog wheel clockwise to display “USERS MODE”.
- ◆ Double click to edit.
- ◆ Turn the jog wheel clockwise to display “User mode” Double click to edit.
- ◆ Choose “Stand Mode” “Basic mode” “Extended mode” , “User Mode A” “User Mode B” and “User Mode C”.
- ◆ Double click to confirm
 - ◆ Long click to exit –“User Mode” then back to main menu by long click again.

EDIT USER A, B, OR C

With this function you can adjust the channel order.

- ◆ Double click jog wheel to access “USERS MODE” menu
- ◆ Turn the jog wheel until display “Edit User”.
- ◆ Double click to access “Edit User” menu.
- ◆ Set up “Max Channel=xxx” and select channel value.
- ◆ Set up “Mode B” and “Mode C” by the same way.
- ◆ Long click to exit – “Edit User” then back to main menu by long click again.

OPTIONS

STATUS

No DMX Mode

Defines the fixture’s state when there is no command signal from the DMX controller. The fixture can either launch a program automatically, close the shutter, or even remain in the state when the last DMX values (Hold) were received. The default setting is “Hold.”

- ◆ Double click jog wheel to access main menu.
- ◆ Turn the jog wheel clockwise then display “Options”.
- ◆ Double click to access “Options” turn the jog wheel to select “Status”.
- ◆ Double click to access “Status” menu The display will show “No DMX Status”.
- ◆ Double click to access “No DMX Status” The display will show “Hold” Turn the jog wheel to select “Close”.
- ◆ Double click to confirm

- ◆ Long click to exit the menu –“Status” then back to main menu by long click again.

Pan Reverse

Reverses the PAN movement.

- ◆ Double click jog wheel to access main menu.
- ◆ Turn the jog wheel clockwise to display “Options”.
- ◆ Double click to access “Options” turn the jog wheel to select “Status”.
- ◆ Double click to access “Status” menu display will show “Pan Reverse”.
- ◆ Double click to access “Pan Reverse”, display will show “OFF” turn the jog wheel to select “ON”.
- ◆ Double click to confirm
- ◆ Long click the jog wheel to exit menu –“Status” then back to main menu by long click again.

Tilt Reverse

Reverses the direction of the TILT movement.

- ◆ Double click jog wheel to access main menu.
- ◆ Turn the jog wheel clockwise to display “Options”.
- ◆ Double click to access “Options” turn the jog wheel to select “Status”.
- ◆ Double click to access to access “Status” menu display will show “Tilt Reverse”.
- ◆ Double click to access “Tilt Reverse” The display will show “OFF” Turn the jog wheel to select “ON”.
- ◆ Double click to confirm
- ◆ Long click the jog wheel to exit menu –“Status” then back to main menu by long click again

Pan Degree

Adjusts the amplitude of the PAN movement at 630° or 540°.

- ◆ Double click jog wheel to access main menu.
- ◆ Turn the jog wheel clockwise then display “Options”.
- ◆ Double click to access “Options” turn the jog wheel to select “Status”.
- ◆ Double click to access “Status” menu The display will show “Pan Degree”.
- ◆ Double click to access to access “Pan Degree” The display will show “540” Turn the jog wheel to select “630”.
- ◆ Double click to confirm
- ◆ Long click the jog wheel to exit menu –“Status” then back to main menu by long click again.

Tilt Degree

Adjusts the amplitude of the TILT movement at 540° or 270°. The 540° function allows you, for instance, to add an accessory to the rear part of the fixture head.

- ◆ Access the menu by pressing the “Mode Esc” key.
- ◆ Use the up/down arrow keys to reach the “OPTION” menu and press “Enter.” Then use the left/right arrow keys to select “Status.” Finally, use the left/right arrow keys to select “Tilt Degree.”
- ◆ Scroll through the different options using the left/right arrows and press “Enter” to confirm.

Feedback

Readjusts the PAN and TILT positions automatically in the event of accidental shifting due to a physical shock.

- ◆ Double click jog wheel to access main menu.
- ◆ Turn the jog wheel clockwise then display “Options”.
- ◆ Double click to access “Options” turn the jog wheel to select “Status”.
- ◆ Double click to access “Status” menu The display will show “Feedback”.
- ◆ Double click to access “Feedback” The display will show “ON” Turn the jog wheel to select “OFF” to deactivate feedback.
- ◆ Double click to confirm

- ◆ Long click the jog wheel to exit menu –“Status” then back to main menu by long click again.

Pan/Tilt Spd

You can choose between four movement speeds, from “Speed 1” to “Speed 4.” The “Speed 1” setting is the fastest.

- ◆ Double click jog wheel to access main menu.
- ◆ Turn the jog wheel clockwise then display “Options”.
- ◆ Double click to access “Options” turn the jog wheel to select “Status”.
- ◆ Double click to access “Status” menu The display will show “Pan/Tilt Spd”.
- ◆ Double click to access to access “Pan/Tilt Spd” The display will show “Speed 1” Turn the jog wheel to select “Speed 1” “Speed 2” “Speed 3” or “Speed 4”.
- ◆ Long click the jog wheel to exit menu –“Status” then back to main menu by long click again

Hibernation — Standby mode

The LEDs and the pan/tilt motors will be powered down if the luminaire receives no DMX signal for several minutes (default setting is OFF). If the DMX signal is restored after this time limit, the luminaire will perform a RESET before resuming normal operation.

- ◆ Double click jog wheel to access main menu.
- ◆ Turn the jog wheel clockwise then display “Options”.
- ◆ Double click to access “Options” turn the jog wheel to select “Status”.
- ◆ Double click to access “Status” menu The display will show “Hibernation”.
- ◆ Double click to access “Hibernation” The display will show “OFF” Turn the jog wheel to select “01M” “02M” . . . “99M”.
- ◆ Double click to confirm
- ◆ Long click to exit menu –“Status” then back to main menu by long click again.

Art-Net to DMX

This function allows you to output through the DMX output the DMX universe selected.

- ◆ Double click jog wheel to access main menu.
- ◆ Turn the jog wheel clockwise then display “Options”.
- ◆ Double click to access “Options” turn the jog wheel to select “Status”.
- ◆ Double click to access “Status” menu The display will show “Art-Net to DMX”.
- ◆ Double click to access “Art-Net to DMX” The display will show “OFF” Turn the jog wheel to select “ON”.
- ◆ Double click to confirm
- ◆ Long click to exit menu – “Status” then back to main menu by long click again.

SERVICE PIN

WARNING! For normal operation the “Service pin” menu information should not be changed. Contact your dealer for more information.

Service PIN

Allows you to enter a password to access the advanced options such as RDM PID, Set IP, Set Device IP, Set LED BIN and Change to bin (pwd: 50).

- ◆ Double click jog wheel to access main menu.
- ◆ Turn the jog wheel clockwise then display “Options”.
- ◆ Double click to access “Options” turn the jog wheel to select “Service PIN”.
- ◆ Double click to access “Service PIN” menu The display will show “Service PIN”.
- ◆ Enter 050

RDM PID

Allows you to set the fixture’s RDM PID code.

- ◆ Double click jog wheel to access main menu.
- ◆ Turn the jog wheel clockwise then display “Options”.
- ◆ Double click to access “Options” turn the jog wheel to select “Service PIN”.
- ◆ Double click to access “Service PIN” menu The display will show “Service PIN”.
- ◆ Enter 050
- ◆ Double click to access “RDM PID”
- ◆ Set the RDM PID
- ◆ Double click to confirm
- ◆ Long click to exit menu –“Service PIN” then back to main menu by Long click again.

Set IP

Allows you to set the fixture’s IP address.

- ◆ Double click jog wheel to access main menu.
- ◆ Turn the jog wheel clockwise then display “Options”.
- ◆ Double click to access “Options” turn the jog wheel to select “Service PIN”.
- ◆ Double click to access “Service PIN” menu The display will show “Service PIN”.
- ◆ Enter 050
- ◆ Double click to access “Set IP” The display will show “XXX.XXX.XXX.XXX”.
- ◆ Set the IP address
- ◆ Double click to confirm
- ◆ Long click to exit menu –“Service PIN” then back to main menu by Long click again.

FAN CONTROL

Fans Control

Allows you to choose the fan speed on the fixture head. The options are AUTO, STAGE, STUDIO or SILENCE.

- ◆ Double click jog wheel to access main menu.
- ◆ Turn the jog wheel clockwise then display “Options”.
- ◆ Double click to access “Options” turn the jog wheel to select “Fans Control”.
- ◆ Double click to access “Fans Control” menu display will show “Head Control”.
- ◆ Double click to access to access “Head Control” The display will show “Auto” Turn the jog wheel to select “Stage” “Studio” or “Silence”
- ◆ Double click to confirm
- ◆ Double click the jog wheel to back to last button press –“Fans Control” then back to main menu by double click again.

DISP.SETTING

Shut off Time

Allows the fixture’s LCD display to be turned off after a period of 2 to 59 minutes.

- ◆ Double click jog wheel to access main menu.
- ◆ Turn the jog wheel clockwise then display “Options”.
- ◆ Double click to access “Options” turn the jog wheel to select “Display Setting”.
- ◆ Double click to access “Display Setting ”menu. The display will show “Shut off Time”.
- ◆ Double click to access “Shut off Time” The display will show “05m” Turn the jog wheel to select “02~60m”.
- ◆ Double click to confirm
- ◆ Long click the jog wheel to back to last button press –“Display Setting” then back to main menu by long click again

Flip Display

Allows you to rotate the display by 180°. This can be highly useful when the fixture is installed with the head facing down.

- ◆ Double click jog wheel to access main menu.
- ◆ Turn the jog wheel clockwise then display "Options".
- ◆ Double click to access "Options" turn the jog wheel to select "Display Setting".
- ◆ Double click to access "Display Setting" menu The display will show "Flip Display".
- ◆ Double click to access "Flip Display" The display will show "OFF" Turn the jog wheel to select "ON".
- ◆ Double click to confirm
- ◆ Long click the jog wheel to exit menu –"Display Setting" then back to main menu by long click again

Key Lock

Activates the automatic keypad lock. If this function is enabled, the keys will be automatically locked 15 seconds after exiting edit mode. Hold the MENU key down for 3 seconds to deactivate this function.

- ◆ Double click jog wheel to access main menu.
- ◆ Turn the jog wheel clockwise then display "Options".
- ◆ Double click to access "Options" turn the jog wheel to select "Display Setting".
- ◆ Double click to access "Display Setting" menu The display will show "Key Lock".
- ◆ Double click to access "Key Lock" The display will show "OFF" Turn the jog wheel to select "ON".
- ◆ Double click to confirm
- ◆ Long click to exit menu –"Display Setting" then back to main menu by long click again.

DispFlash

Causes the display to flash as a warning that there is no DMX signal.

- ◆ Double click jog wheel to access main menu.
- ◆ Turn the jog wheel clockwise then display "Options".
- ◆ Double click to access "Options" turn the jog wheel to select "Display Setting".
- ◆ Double click to access "Display Setting" menu The display will show "DispFlash".
- ◆ Double click to access "DispFlash" The display will show "OFF" Turn the jog wheel to select "ON".
- ◆ Long click to exit menu—"Display Setting" then back to main menu by long click again.

SIGNAL SELECT

Signal Select

This menu allows you to choose which type of signal is used to control the fixture (DMX, WDMX, Art-Net or sACN).

- ◆ Double click jog wheel to access main menu.
- ◆ Turn the jog wheel clockwise then display "Options".
- ◆ Double click to access "Options" turn the jog wheel to select "Signal Select".
- ◆ Double click to access "Signal Select" The display will show "DMX"
- ◆ Turn the jog wheel to select "DMX" "WDMX" "Art--Net" or "sACN".
- ◆ Double click to confirm
- ◆ Long click to exit menu –"Signal Select" then back to main menu by long click again.

TEMP. C/F

Allows you to select the unit of measurement for the temperature values, in either Celsius or Fahrenheit.

- ◆ Double click jog wheel to access main menu.

- ◆ Turn the jog wheel clockwise then display "Options".
- ◆ Double click to access "Options" turn the jog wheel to select "Temperature C/ F".
- ◆ Double click to access "Temperature C/ F" The display will show "Fahrenheit" Turn the jog wheel to select "Celsius".
- ◆ Double click to confirm
- ◆ Long click to exit menu –"Temperature C/ F" then back to main menu by Long click again.

INITIAL POS.

Controls the initial position of the fixture's effects.

- ◆ Double click jog wheel to access main menu.
- ◆ Turn the jog wheel clockwise then display "Options".
- ◆ Double click to access "Options" turn the jog wheel to select "Initial Pos."
- ◆ Double click to access "Initial Pos." The display will show "PAN=XXX".
- ◆ Long click to exit menu –"Initial Pos." then back to main menu by long click again.

WIRELESS DMX

This menu allows you to activate, activate and resend data via XLR plug or reset wireless pairing.

- ◆ Double click jog wheel to access main menu.
- ◆ Turn the jog wheel clockwise then display "Options".
- ◆ Double click to access "Options" turn the jog wheel to select "Wireless DMX".
- ◆ Double click to access "Wireless DMX" The display will show "Activate WDMX" Turn the jog wheel to select "Act&Data Out" or "Rest WDMX" to reset Wireless pairing
- ◆ Double click the jog wheel to back to last button press –"Wireless DMX" then back to main menu by double click again.

TRIGGER

DMX Value Disp.

Allows you to view the DMX value received for each setting. The "ALL" option will display only the setting being edited.

- ◆ Double click jog wheel to access main menu.
- ◆ Turn the jog wheel clockwise then display "Options".
- ◆ Double click to access "Options" turn the jog wheel to select "Trigger".
- ◆ Double click to access "Trigger" menu The display will show "DMX Value Disp".
- ◆ Double click to access "DMX Value Disp" The display will show "PAN=.....".
- ◆ Double click the jog wheel to back to last button press –"Trigger" then back to main menu by double click again.

Set To Slave

Sets the fixture to SLAVE Mode for receiving instructions from a master luminaire (see Master/Save mode settings, below).

- ◆ Double click jog wheel to access main menu.
- ◆ Turn the jog wheel clockwise then display "Options".
- ◆ Double click to access "Options" turn the jog wheel to select "Trigger".
- ◆ Double click to access "Trigger" menu The display will show "Set To Slave".
- ◆ Double click to access "Set To Slave" The display will show "Slave1" "Slave2" "Slave3".
- ◆ Double click the jog wheel to back to last button press –"Trigger" then back to main menu by double click again.

Auto Program

Allows you to run an internal program (a sequence of scenes) by selecting whether the fixture is operating alone or as a master.

- ◆ Double click jog wheel to access main menu.
- ◆ Turn the jog wheel clockwise then display“Options”.
- ◆ Double click to access “Options” turn the jog wheel to select “Trigger”.
- ◆ Double click to access “Trigger”menu The display will show “Auto Program”.
- ◆ Double click to access “Auto Program” The display will show “Master” “Alone”.
- ◆ Double click the jog wheel to back to last button press –“Trigger” then back to main menu by double click again.

Note: See “AUTO” menu to create internal programs.

RESET DEFAULT

Restores the factory default settings on the fixture.

- ◆ Double click jog wheel to access main menu.
- ◆ Turn the jog wheel clockwise then display“Options”.
- ◆ Double click to access“Options” turn the jog wheel to select “Reset Default”.
- ◆ Double click to access“Reset Default”menu The display will show “OFF” Turn the jog wheel to select“ON”.
- ◆ Double click the jog wheel to back to last button press –“Reset Default” then back to main menu by double click again.

INFO

TIME INFO.

Current Time

Shows the number of hours the fixture has been operating since it was powered on.

- ◆ Double click jog wheel to access main menu.
- ◆ Turn the jog wheel clockwise then display“Info”.
- ◆ Double click to access “Info” turn the jog wheel to select “Time Info.”.
- ◆ Double click to access “Time Info.” The display will show “Current Time”.
- ◆ Double click to access “Current Time” The display will show “XXXX (Hours)”.
- ◆ Double click the jog wheel to back to last button press –“Time Info”then back to main menu by double click again.

Ttl Life Hrs

Shows the fixture’s total number of hours of operation.

- ◆ Double click jog wheel to access main menu.
- ◆ Turn the jog wheel clockwise then display“Info”.
- ◆ Double click to access “Info” turn the jog wheel to select “Time Info.”.
- ◆ Double click to access “Time Info.” The display will show “Ttl Life Hrs”.
- ◆ Double click to access “Ttl Life Hrs” The display will show “XXXX (Hours)”.
- ◆ Double click the jog wheel to back to last button press –“Time Info” then back to main menu by double click again.

Last Run Hrs

Shows the fixture’s length of operation since the last time this counter was reset.

- ◆ Double click jog wheel to access main menu.
- ◆ Turn the jog wheel clockwise then display“Info”.
- ◆ Double click to access “Info” turn the jog wheel to select “Time Info.”.
- ◆ Double click to access “Time Info.” The display will show “Last Run Hrs”.
- ◆ Double click to access “Last Run Hrs” The display will show “XXXX (Hours)”.
- ◆ Double click the jog wheel to back to last button press –“Time Info”

then back to main menu by double click again.

Timer PIN

The “Timer PIN” is the password required to reset the counter for “Last Run Hrs.” The PWD is 038.

- ◆ Double click jog wheel to access main menu.
- ◆ Turn the jog wheel clockwise then display“Info”.
- ◆ Double click to access “Info” turn the jog wheel to select “Time Info.”.
- ◆ Double click to access “Time Info.” The display will show “Timer PIN”.
- ◆ Double click to access “Timer PIN” The display will show “Password=038”.
- ◆ Double click the jog wheel to back to last button press –“Time Info” then back to main menu by double click again.

CLR LAST RUN

After entering the “Timer PIN”, you can reset the value for “Last Run Hrs” through this menu.

- ◆ Double click jog wheel to access main menu.
- ◆ Turn the jog wheel clockwise then display“Info”.
- ◆ Double click to access “Info” turn the jog wheel to select “Time Info.”.
- ◆ Double click to access “Time Info.” The display will show “Clear Last Run”.
- ◆ Double click to access “Clear Last Run” The display will show “OFF” turn the jog wheel to select“ON”.
- ◆ Double click the jog wheel to back to last button press –“Time Info” then back to main menu by double click again.

TEMP. INFO

Head Temp.

Shows the current temperature of the fixture head.

- ◆ Double click jog wheel to access main menu.
- ◆ Turn the jog wheel clockwise then display“Info”.
- ◆ Double click to access “Info” turn the jog wheel to select “Temp Info”.
- ◆ Double click to access “Temp Info” The display will show “Head Temp.”.
- ◆ Double click to access “Head Temp.” The display will show “XXX °C/ °F”.
- ◆ Double click the jog wheel to back to last button press –“Temp Info” then back to main menu by double click again.

SOFTWARE VER

Displays the software version of the fixture.

- ◆ Double click jog wheel to access main menu.
- ◆ Turn the jog wheel clockwise then display“Info”.
- ◆ Double click to access “Info” turn the jog wheel to select “Software Ver”.
- ◆ Double click to access “Software Ver” The display will show “Ver x.x.x”.
- ◆ Double click the jog wheel to back to last button press –“Software Ver” then back to main menu by double click again.

NETWORK

This menu directly displays the following network information for the fixture: IP address, subnet mask and MAC address

- ◆ Double click jog wheel to access main menu.
- ◆ Turn the jog wheel clockwise then display“Info”.
- ◆ Double click to access “Info” turn the jog wheel to select “Network”.
- ◆ Double click to access “Network” The display will show“IP” Turn the jog wheel to select“Mask” “Mac”.
- ◆ Double click the jog wheel to back to last button press –“Network” then back to main menu by double click again.

TEST

HOME

Allows you to reset the functions. You can select these functions by adjusting the channel.

- ◆ Double click jog wheel to access main menu.
- ◆ Turn the jog wheel clockwise then display "Test".
- ◆ Double click to access "Test" turn the jog wheel to select "Home".
- ◆ Double click to access "Home" The display will show "All" Turn the jog wheel to select "All" "Pan&Tilt" "Color" "Gobo" or "Other".
- ◆ Double click the jog wheel to back to last button press – "Test" then back to main menu by double click again.

TEST CHANNEL

Tests each of the fixture's settings (e.g., PAN, TILT).

- ◆ Double click jog wheel to access main menu.
- ◆ Turn the jog wheel clockwise then display "Test".
- ◆ Double click to access "Test" turn the jog wheel to select "Test Channel".
- ◆ Double click to access "Test Channel" The display will show "Pan" Turn the jog wheel to select other channel.
- ◆ Double click the jog wheel to back to last button press – "Test" then back to main menu by double click again.

MANUAL CTRL.

Allows you to access all the fixture's settings manually (e.g., PAN, TILT). The shutter and the electronic dimmer are by default 100% open.

- ◆ Double click jog wheel to access main menu.
- ◆ Turn the jog wheel clockwise then display "Test".
- ◆ Double click to access "Test" turn the jog wheel to select "Manual control".
- ◆ Double click to access "Manual control" The display will show "PAN=XXX".
- ◆ Double click the jog wheel to back to last button press – "Test" then back to main menu by double click again.

CALIBRATION

Calibrates certain settings such as Pan, Tilt and Zoom. The password required to access the calibration function is 050.

- ◆ Double click jog wheel to access main menu.
- ◆ Turn the jog wheel clockwise then display "Test".
- ◆ Double click to access "Test" turn the jog wheel to select "Calibration".
- ◆ Double click to access "Calibration" The display will show "Password=050".
- ◆ Double click the jog wheel to back to last button press – "Test" then back to main menu by double click again.

PRESET

SELECT PROG.

Allows you to select the program for "Program Run."

EDIT PROG.

Allows you to edit internal programs.

EDIT SCENES

Allows you to edit scenes within the internal programs.

SCENES INPUT

The luminaire features a DMX recorder, which can receive the scenes programmed on your DMX controller. Set the desired number of scenes from the control panel. Then run the scenes from your controller. They will be automatically transmitted to the GHIBLI.

MASTER/SLAVE MODE SETTINGS

A MASTER fixture can send up to 3 different sets of data to a SLAVE fixture (e.g., a MASTER fixture can control 3 different SLAVE fixtures which will each perform 3 different programs). The MASTER fixture sends the 3 programs in a continuous loop.

The SLAVE fixture receives data from the MASTER fixture according to the group to which the SLAVE fixture is assigned. For example, if the SLAVE fixture has been assigned to "Slave 1" in the menu "Set to Slave", the MASTER fixture sends "Auto Program Part 1" to this SLAVE fixture. If it was assigned to "Slave 2", the SLAVE fixture would receive the program "Auto Program Part 2" from the MASTER fixture.

To launch a program, follow this procedure:

1. Slave Settings - SLAVE fixture adjustment
Use the buttons to select "Function Mode."
Press ENTER to confirm.
Use the buttons to select "Set slave to."
Press ENTER to confirm.
Use the buttons to select "Slave 1", "Slave 2" or "Slave 3."
Press ENTER to confirm.
Press MODE/ESC to return to the main menu.
2. Automatic Program Run
Use the buttons to select "Function Mode."
Press ENTER to confirm.
Use the buttons to select "Auto Program."
Press ENTER to confirm.
Use the buttons to select "Master" or "Alone." "Master" sets the fixture as the master.
Press ENTER to confirm.
Press MODE/ESC to return to the main menu.
3. Program selection for Auto Pro Part
Use the buttons to select "Edit program."
Press ENTER to confirm.
Use the buttons to select "Select programs."
Press ENTER to confirm.
Select "Auto Program Part 1", "Auto Program Part 2" or "Auto Program Part 3", for the Slave program to be sent. Selecting "Part 1" will cause the SLAVE to run the same program as the MASTER fixture.
Press ENTER to confirm.
Press MODE/ESC to return to the main menu.
4. Program selection for Edit Program
Use the buttons to select "Edit program."
Press ENTER to confirm.
Use the buttons to select "Edit program."
Press ENTER to confirm.
Use the buttons to select the desired program.
You can edit specific scenes in a given program.
Press ENTER to confirm.
Press MODE/ESC to return to the main menu.
5. Automatic Scene Recording
Use the buttons to select "Edit program."
Press ENTER to confirm.
Use the buttons to select "Edit scenes."
Use the buttons to select the number of desired scenes. (maximum

amount: 250 scenes)
 Press ENTER to confirm.
 Press MODE/ESC to return to the main menu.

Example:

"Program 2" includes scenes: 10, 11, 12, 13.

"Program 4" includes scenes: 8, 9, 10.

"Program 6" includes scenes: 12, 13, 14, 15.

"Auto Program Part 1" is "Program 2."

"Auto Program Part 2" is "Program 3."

"Auto Program Part 3" is "Program 6."

The 3 groups of SLAVE fixtures run the "Auto Program" function in the following sequence:

Part 1:



Part 2:

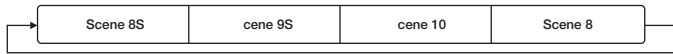

Part 3:

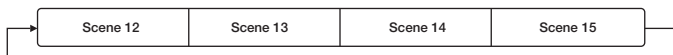

THE following chart shows the functions and corresponding values for each DMX channel according to mode whether Standard (St), Basic (Ba) or Extended (Ex):

| DMX channel's functions and their values (58DMX channels): | | | | |
|--|-----------------------------------|----|---------|-----------------------------------|
| Mode/Channel | | | Value | Function |
| St | Ba | Ex | | |
| 1 | 1 | 1 | | PAN Movement 8bit |
| | | | 0-255 | Pan Movement |
| 2 | | 2 | | Pan Fine 16bit |
| | | | 0-255 | Fine control of Pan movement |
| 3 | 2 | 3 | | TILT Movement 8bit |
| | | | 0-255 | Tilt Movement |
| 4 | | 4 | | Tilt Fine 16bit |
| | | | 0-255 | Fine control of Tilt movement |
| 5 | 3 | 5 | | Speed Pan/Tilt movement: |
| | | | 0-225 | max to min speed |
| | | | 226-235 | blackout by movement |
| | | | 236-245 | blackout by all wheel changing |
| | | | 246-255 | no function |
| 6 | 4 | 6 | | Shutter, strobe |
| | | | 0-31 | Shutter closed |
| | | | 32-63 | No function (shutter open) |
| | | | 64-95 | Strobe effect slow to fast |
| | | | 96-127 | No function (shutter open) |
| | | | 128-159 | Pulse-effect in sequences |
| | | | 160-191 | No function (shutter open) |
| 192-223 | Random strobe effect slow to fast | | | |
| | | | 224-255 | No function (shutter open) |
| 7 | 5 | 7 | | Dimmer intensity: |
| | | | 0-255 | Intensity 0 to 100% |
| | | 8 | | Fine Dimmer intensity: |
| | | | 0-255 | Dimmer intensity fine |
| 8 | 6 | 9 | | Chase Patterns |
| | | | 0-9 | Open |
| | | | 10-19 | Chase 1 |
| | | | 20-29 | Chase 2 |
| | | | 30-39 | Chase 3 |
| | | | 40-49 | Chase 4 |
| | | | 50-59 | Chase 5 |
| | | | 60-69 | Chase 6 |
| | | | 70-79 | Chase 7 |
| | | | 80-89 | Chase 8 |
| | | | 90-99 | Chase 9 |
| | | | 100-109 | Chase 10 |
| | | | 110-119 | Chase 11 |
| | | | 120-129 | Chase 12 |
| 130-139 | Chase 13 | | | |
| | | | 140-255 | Reserved |
| 9 | 7 | 10 | | Chase Speed |
| | | | 0-125 | Fast to Slow Backward |
| | | | 126-130 | Stop |
| | | | 131-255 | Slow to Fast Forward |
| 10 | 8 | 11 | | Chase Fade |
| | | | 0-255 | Fade Chase |
| 11 | 9 | 12 | | Zoom : |
| | | | 0-255 | Zoom adjustment from small to big |

DMX CHART

| DMX channel's functions and their values (58DMX channels): | | | | |
|--|----|----|---------|--|
| Mode/Channel | | | Value | Function |
| St | Ba | Ex | | |
| | | 13 | | Zoom Fine: |
| | | | 0-255 | Zoom adjustment Fine |
| 12 | 10 | 14 | | Focus : |
| | | | 0-255 | Continuous adjustment from near to far |
| | | 15 | | Focus Fine: |
| | | | 0-255 | Continuous adjustment Fine |
| 13 | 11 | 16 | | Auto Focus : |
| | | | 0-50 | Auto Focus Off |
| | | | 51-100 | 5m |
| | | | 101-150 | 7.5m |
| | | | 151-200 | 10m |
| | | | 201-255 | 15m |
| 14 | 12 | 17 | | AutoFocus Fine: |
| | | | 0-255 | Continuous adjustment Fine |
| 15 | 13 | 18 | | Color Wheel: |
| | | | 0-17 | Open / white |
| | | | 18-35 | Color 1 (CRI Filter) |
| | | | 36-53 | Color 2 (Congo Blue) |
| | | | 54-71 | Color 3 (Green) |
| | | | 72-89 | Color 4 (Orange) |
| | | | 90-107 | Color 5 (Light Blue) |
| | | | 108-127 | Color 6 (Red) |
| | | | 128-189 | Forward rainbow effect from fast to slow |
| | | | 190-193 | No rotation |
| | | | 194-255 | Backward rainbow effect from slow to fast |
| | | 19 | | Color Wheel Fine : |
| | | | 0-255 | Color Wheel colour change to any position Fine |
| 16 | 14 | 20 | | Cyan Color : |
| | | | 0-255 | Cyan (0-white, 255-100% Cyan) |
| | | 21 | | Cyan Color Fine : |
| | | | 0-255 | Cyan Fine |
| 17 | 15 | 22 | | Magenta Color : |
| | | | 0-255 | Magenta (0-white, 255-100% magenta) |
| | | 23 | | Magenta Color Fine : |
| | | | 0-255 | Magenta Fine |
| 18 | 16 | 24 | | Yellow Color : |
| | | | 0-255 | Yellow (0-white, 255-100% Yellow) |
| | | 25 | | Yellow Color Fine : |
| | | | 0-255 | Yellow Fine |
| 19 | 17 | 26 | | CTO Color : |
| | | | 0-255 | CTO (0-white, 255-100% CTO) |
| | | 27 | | CTO Color Fine : |
| | | | 0-255 | CTO Fine |

| DMX channel's functions and their values (58DMX channels): | | | | |
|--|----|----|---------|--|
| Mode/Channel | | | Value | Function |
| St | Ba | Ex | | |
| 20 | 18 | 28 | | Rotating gobos, cont. rotation 1: |
| | | | 0-9 | Open |
| | | | 10-19 | Rot. gobo 1 |
| | | | 20-29 | Rot. gobo 2 |
| | | | 30-39 | Rot. gobo 3 |
| | | | 40-49 | Rot. gobo 4 |
| | | | 50-59 | Rot. gobo 5 |
| | | | 60-69 | Rot. gobo 6 |
| | | | 70-77 | Rot. Gobo 7 |
| | | | 78-93 | Gobo 1 shake slow to fast |
| | | | 94-109 | Gobo 2 shake slow to fast |
| | | | 110-125 | Gobo 3 shake slow to fast |
| | | | 126-141 | Gobo 4 shake slow to fast |
| | | | 142-157 | Gobo 5 shake slow to fast |
| | | | 158-173 | Gobo 6 shake slow to fast |
| | | | 174-189 | Gobo 7 shake slow to fast |
| | | | 190-221 | Gobo wheel rotation forwards from fast to slow |
| | | | 222-223 | No rotation |
| | | | 224-255 | Gobo wheel rotation f backwards from slow to fast |
| 21 | 19 | 29 | | Rotating gobo index,rotating gobo rotation 1: |
| | | | 0-127 | Gobo indexing |
| | | | 128-189 | Forwards gobo rotation from fast to slow |
| | | | 190-193 | No rotation |
| | | | 194-255 | Backwards gobo rotation from slow to fast |
| | | 30 | | Rotating gobo indexing Fine 1: |
| | | | 0-255 | Fine indexing |
| 22 | 20 | 31 | | Fixed Gobo2 : |
| | | | 0-21 | open |
| | | | 22-31 | Gobo 1 |
| | | | 32-41 | Gobo 2 |
| | | | 42-51 | Gobo 3 |
| | | | 52-61 | Gobo 4 |
| | | | 62-71 | Gobo 5 |
| | | | 72-81 | Gobo 6 |
| | | | 82-91 | Gobo 7 |
| | | | 92-101 | Gobo 8 |
| | | | 102-112 | Gobo 1 shake slow to fast |
| | | | 113-123 | Gobo 2 shake slow to fast |
| | | | 124-134 | Gobo 3 shake slow to fast |
| | | | 135-145 | Gobo 4 shake slow to fast |
| | | | 146-156 | Gobo 5 shake slow to fast |
| | | | 157-167 | Gobo 6 shake slow to fast |
| | | | 168-178 | Gobo 7 shake slow to fast |
| | | | 179-189 | Gobo 8 shake slow to fast |
| | | | 190-221 | Clock-wise scroll from fast to slow |
| | | | 222-223 | Reserved |
| | | | 224-255 | Counter clock-wise scroll from slow to fast |
| 23 | 21 | 32 | | Animation wheel: |
| | | | 0-7 | open |
| | | | 8-127 | Forwards rotation from fast to slow |
| | | | 128-135 | No rotation |
| | | | 136-255 | Backwards rotation from slow to fast |
| 24 | 22 | 33 | | Iris: |
| | | | 0-191 | Max. diameter to Min.diameter |
| | | | 192-223 | Pulse closing fast to slow |
| | | | 224-255 | Pulse opening slow to fast |

| DMX channel's functions and their values (58DMX channels): | | | | |
|--|----|----|---------|--|
| Mode/Channel | | | Value | Function |
| St | Ba | Ex | | |
| | | 34 | | Iris Fine: |
| | | | 0-255 | Iris Fine |
| | | | | Prism |
| 25 | 23 | 35 | 0-127 | Open |
| | | | 128-255 | Prism |
| | | | | Rotating prism index, rotating prism rotation |
| | | | 0-127 | Prism indexing |
| | | | 128-189 | Forwards prism rotation from fast to slow |
| | | | 190-193 | No rotation |
| | | | 194-255 | Backwards prism rotation from slow to fast |
| | | 37 | | Rotating prism indexing Fine : |
| | | | 0-255 | Fine indexing |
| | | | | Frost 1: |
| 27 | 25 | 38 | 0-255 | 0-100% |
| | | | | Frost 2: |
| 28 | 26 | 39 | 0-255 | 0-100% |
| | | | | Blade 1A : |
| | | | 0-255 | Open to Close |
| | | 41 | | Blade 1A Fine : |
| | | | 0-255 | Open to Close Fine |
| | | | | Blade 1B : |
| 30 | 28 | 42 | 0-255 | Open to Close |
| | | | | Blade 1B Fine: |
| | | | 0-255 | Open to Close Fine |
| | | | | Blade 2A: |
| | | | 0-255 | Open to Close |
| | | 45 | | Blade 2A Fine : |
| | | | 0-255 | Open to Close Fine |
| | | | | Blade 2B: |
| 32 | 30 | 46 | 0-255 | Open to Close |
| | | | | Blade 2B Fine: |
| | | | 0-255 | Open to Close Fine |
| | | | | Blade 3A : |
| 33 | 31 | 48 | 0-255 | Open to Close |
| | | | | Blade 3A Fine: |
| | | | 0-255 | Open to Close Fine |
| | | | | Blade 3B: |
| 34 | 32 | 50 | 0-255 | Open to Close |
| | | | | Blade 3B Fine : |
| | | | 0-255 | Open to Close Fine |
| | | | | Blade 4A : |
| 35 | 33 | 52 | 0-255 | Open to Close |
| | | | | Blade 4A Fine : |
| | | | 0-255 | Open to Close Fine |
| | | | | Blade 4B: |
| 36 | 34 | 54 | 0-255 | Open to Close |
| | | | | Blade 4B Fine : |
| | | | 0-255 | Open to Close Fine |
| | | | | All Blade Rotation : |
| 37 | 35 | 56 | 0-255 | All Blade Rotation |
| | | | | All Blade Rotation Fine : |
| | | | 0-255 | All Blade Rotation Fine |

| DMX channel's functions and their values (58DMX channels): | | | | |
|--|----|----|---------|--|
| Mode/Channel | | | Value | Function |
| St | Ba | Ex | | |
| | | | | Control, Reset : |
| | | | 0-9 | Not used |
| | | | 10-14 | Display Off |
| | | | 15-19 | Display On |
| | | | 20-24 | Display invert Off |
| | | | 25-29 | Display invert On |
| | | | 30-34 | Auto Fan Mode |
| | | | 35-39 | Stage Fan Mode |
| | | | 40-44 | Studio Fan Mode |
| | | | 45-49 | Silent Fan Mode |
| | | | 50-54 | Square Dim |
| | | | 55-59 | Linear Dim |
| 38 | 36 | 58 | 60-64 | 1,2kHz |
| | | | 65-69 | 2,4kHz |
| | | | 70-74 | 16kHz |
| | | | 75-76 | Gobo correction Off |
| | | | 77-78 | Gobo correction On |
| | | | 79 | Not Used |
| | | | 100-119 | Internal program 1 (scene 1~8 of EEPROM) |
| | | | 120-139 | Internal program 2 (scene 9~16 of EEPROM) |
| | | | 140-159 | Internal program 3 (scene 17~24 of EEPROM) |
| | | | 160-179 | Internal program 4 (scene 25~32 of EEPROM) |
| | | | 180-199 | Internal program 5 (scene 33~40 of EEPROM) |
| | | | 200-219 | Internal program 6 (scene 41~48 of EEPROM) |
| | | | 220-239 | Internal program 7 (scene 49~56 of EEPROM) |
| | | | 240-255 | Internal program 8 (scene 49~56 of EEPROM) |

ERROR MESSAGES

When you turn on the GHIBLI, it will first perform an automatic reset. The display may show "Err channel is XX" indicating there is a problem with one or more of the channels. "XX" represents channel 1, 2, 3, 4, 5 or 6, which contain the testing sensor for positioning. For example, the message, "Err channel is Pan movement", indicates an error in channel 1. If there is an error on channel 1 and channel 3 at the same time, the following error message may appear: "Err channel is Pan movement", "Err channel is Tilt movement". The system will flash twice, and the fixture will generate a second reset. If the error message persists after more than two resets, the channels showing errors will not work properly but the other channels will function normally.

Please contact your authorized dealer or manufacturer for service and do not attempt to repair the luminaire yourself.

PAN- movement Er

(PAN-yoke movement error): This message will appear after the reset if the yoke's magnetic-indexing circuit malfunctions (failed sensor or magnet missing) or the stepping-motor is defective (also caused by its driving IC on the main PCB). The PAN- movement does not return to the default position after the reset.

TILT- movement Er

(TILT-head movement error): This message will appear after the reset if the head's magnetic-indexing circuit malfunctions (sensor failed or magnet missing) or the stepping-motor is defective (also caused by its

driving IC on the main PCB). The TILT- movement does not return to the default position after the reset.

CARE AND MAINTENANCE

The care and maintenance of your GHIBLI should be ensured by a qualified technician. Your GHIBLI requires regular servicing. The frequency depends essentially on its operating conditions and environment. Intensive use in a dusty environment, or a lack of ventilation around the fixture, may disrupt operation, result in overheating and cause damage that is not covered by the warranty.

WARNING!

Disconnect from mains before servicing.

UPDATING THE LUMINAIRE

Ayrton is continually upgrading this product line. It is therefore possible that a new software version is available that will increase the unit's capabilities.

Updates are performed using Ayrton's update box. Contact your dealer for more information.

To display the version of your device, go into the "Info" menu and select "Software version" (see options details under the "INFO" menu). It is advisable to use the same software version for multiple fixtures.

CLEANING

Your GHIBLI requires cleaning at regular intervals. Be aware that accumulated dust and residue on the air vents, body and glass of the fixture may reduce efficiency and impair proper operation.

Before cleaning, disconnect the power cable from source.

Use compressed air to blow away dust particles accumulated on and between the cooling fins at the rear of the luminaire's optical system.

Clean the glass of the fixture with a slightly damp soft cloth. When necessary, use a non-alcohol-based glass cleaner. Never use harsh solvents!

WARNING!

Never use alcohol or any chemical agent to clean the optical system of an Ayrton product.

COMPLIANCE CHECK

Your installation should be checked regularly by certified service center. In addition, the following should be checked once a year by a qualified technician:

- The fixture's attachment system must be correctly installed and show no sign of corrosion.
- The fixture's mounting bracket should not be distorted in any way or

show any trace of corrosion.

- The safety cable should be attached at the appropriate spot.
- Mechanical parts should show no sign of wear.
- The electrical cables should show no sign of wear, cuts or splices.

TECHNICAL SPECIFICATIONS

OPTICAL

- High-efficiency optical system
- Opening angle of the beam: 7° to 56°

LIGHT SOURCE

- White LED module
- Brightness: up to 24,000 lumens
- Estimated lifespan of LED emitters: 25,000 hours
- Guaranteed "no-flicker" effect perfectly suited for television applications and all video recorded events

DIMMER, STROBE

- Electronic dimmer for light adjustment from 0 to 100% without color change (16-bit)
- High-speed strobe effect in white or color at 1 to 25 flashes/second
- Pre-programmed variable strobe effects

GOBO SIZE

- GOBO size : 30mm diameter
- Image size : 22mm diameter

SOFTWARE FEATURES

- Full menus for setting DMX address and advanced functions
- Compatible with the DMX/RDM (Remote Device Management) protocol
- Pre-programmed macro modes
- Information menu including: timer, temperature, software version, etc.

CONTROL

- USITT DMX512 – ArtNet - sACN
- Automatic features for managing your luminaire without a DMX console
- DMX RDM-compatible
- Clicking jog wheel
- DMX512 input/output
- Choice of 3 DMX modes (from 36 to 58 channels)
- Wireless System: LumenRadio wireless CRMX RDM receiver

POWER SUPPLY

- Electronic power distribution with Power Factor Correction (PFC) from 110-240 VAC, 50/60 Hz
- 900 Watt maximum power
- Power supply via powerCON Trueone connector
- Supplied power cable without plug
- Optional battery for addressing without external power source: Li-ion ICR14500 ≥ 350mAh – 3,7V

COOLING

- Advanced forced-air cooling system
- Self-adjusting fan for reduced noise level (in AUTO mode)
- User-selectable air-cooling modes

CONSTRUCTION

- Covers: molded PC-ABS thermoplastic, class V0 (fire retardant)

- Chassis: steel plates and aluminum
- 2 handles for transport
- Protection rating: IP20 (indoor use only)
- Finish: Carbon black

INSTALLATION

- 2 OMEGA brackets with quarter-turn locks included
- Safety cable attachment not included

OPERATING PARAMETERS

- Operating positions: on floor or attached to a support
- Maximum authorized ambient temperature (Ta Max): 45°C
- Minimum authorized ambient temperature (Ta Min): -5°C
- Minimum projection distance: 5 m

DIMENSIONS

- Product: 494 mm x 729 mm x 281 mm (L x H x D)
- Protective foam: 655 mm x 590 mm x 555mm (L x H x D)

WEIGHT

- Product: 35,6 kg
- Product in packaging with accessories: 50,6kg

PRODUCT CODE

- 011450: GHIBLI AUTOMATED LUMINAIRE

FOAM FOR FLIGHT CASE

GHIBLI is delivered in a carton packed with a dense, protective foam surrounding the fixture. This reusable protective shell is intended for a flight case that can be custom built for the luminaire.

AYRTON does not offer custom flight cases for the GHIBLI. This accessory is to be provided by the user.

The main dimensions of the protective shell appear in the following diagram:

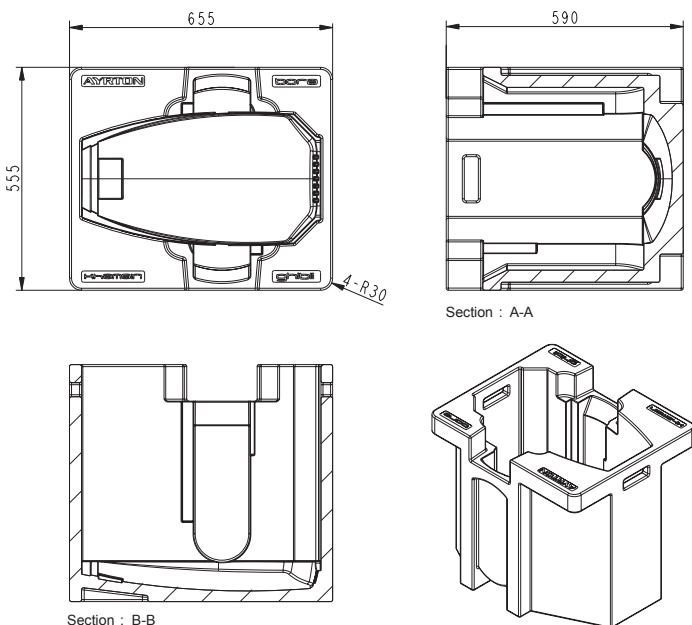

WARRANTY

The AYRTON GHIBLI fixture is guaranteed against manufacturing defects for the duration of two (2) years from the date of purchase.

This warranty does not cover the unit for evidence of physical shock or damage caused by abuse or any use not in accordance with the operating conditions set forth in the present user manual.

In addition, cosmetic defects caused by the normal wear and tear of the unit are not covered under the warranty.

Any modification to the fixture will void the warranty. AYRTON cannot under any circumstances be held liable for quality and conformity regarding the installation of this product, which is the responsibility of the installer.

Broken glass lenses on the GHIBLI, and any damage that could arise thereof, are excluded from the warranty. Any possible cosmetic defects, provided you report them to your AYRTON dealer upon unpacking the device and before use, may be covered by the warranty.

Note:

The manufacturer is not responsible for any errors or omissions that may occur in this document. All information contained in this manual is subject to change without notice.



AYRTON

Digital Lighting